

## NC1

### A cargo bike for all occasions

Our ambition was not to reinvent the cargo bike, but to bring the existing one to the next evolutionary stage through technical finesse.

Thanks to the latest generation of electric drive systems from BOSCH, even the fully loaded NC1 can be ridden effortlessly and smoothly even by untrained people and over longer distances and inclines.

When developing the Cargobike, the NICOLAI designers paid special attention to areas that seem contradictory at first glance. The NC1 should be stable, resilient & safe, but also light & agile. In practice, the whole thing looks like this:

Two battery compartments are sensibly placed under the cargo area. They bring more weight towards the front wheel, which has a positive effect on the driving style due to the lowered centre of gravity.

The robust steering linkage with double end stops prevents turning over when steering on the one hand, and on the other hand enables the smallest possible turning circle through a large steering angle. In other words, NC1 riders turn very smoothly even in tighter bends and keep their balance well.

The decision to fit a 4-piston brake system and somewhat thicker-walled brake discs on both the front and rear wheels has proved successful and ensures a safe braking feeling even with a fully loaded NC1 and downhill.

The hydraulically lowerable seat post ensures safer handling when stationary and can be extended again while riding by pressing a button on the handlebars.

New from NICOLAI is the lockable bipod stand. It can be folded up effortlessly by stepping on a foot pedal with your own body weight and folded down again just as easily by pushing the Cargobike forwards and offers the additional comfort of not needing any further locking devices. When jacked up, the NC1 is very stable. Tipping during the loading process is impossible.

Speaking of cargo : Thanks to four parallel AIRLINE rails on a freely accessible loading area and the matching equipment, the NC1 always offers a solution for securing the load.

The whole thing is rounded off by wider tyres, with which the NC1 cuts a good figure even on bad roads.

The NICOLAI Cargobike has a straightforward and timeless design. With its various practical features, it can provide real added value in everyday life. No matter whether bulky or sensitive goods, children & shopping or the friend on four paws are to be transported, the NC1 fulfills today's mobility requirements in a durable manner.

# NC1

## Features

### **GATES belt drive**

The quiet and virtually maintenance-free GATES belt made of carbon fibre is the perfect choice for a cargo bike. It lasts much longer than a chain and also transmits the additional torque of the motor without stretching.

### **ENVILO continuously variable gears**

The ENVILO gearstick in the cargo variant CO is the first choice when it comes to coping with the hectic daily routine in city traffic in a relaxed manner. In every situation, the right gear ratio can be selected with the manual version, even under load and when accelerating.

The automatic ENVILO even makes manual shifting completely superfluous and automatically ensures that the right gear ratio is always available.

Both the manual and automatic ENVILO gearstick systems offer maximum comfort with minimum maintenance.

### **ROHLOFF gear shifting as an option**

The proven ROHLOFF 14-speed manual transmission is available as an option for long tours where maximum range and efficiency are important. The ROHLOFF 500/14 Classic TS also achieves this with minimum maintenance and maximum stability.

### **BOSCH drive system**

The BOSCH CX motor from the smart system of the latest generation makes all loads and climbs child's play with a powerful 85 Nm. The Kiox display shows all relevant data and can be paired with your own smartphone through the Flow app.

### **BOSCH PowerTube and DualBattery**

With 750 Wh, the new PowerTubes are equipped with significantly more capacity than before. Together with the possibility of having a second battery on board, this results in previously unknown ranges.

### **Lowerable seat post (NICOLAI version)**

Smooth-running lowerable seat post for adjusting the saddle height and safe standing at traffic lights. The NC1 can thus be used by different riders without any modifications.

### **Loading area with AIRLINE system**

The continuous 70x50cm loading area offers space for all kinds of loads up to 70 kg. The integrated AIRLINE system makes it easy to attach accessories.

### **Lockable stand**

The lockable double stand secures the NC1 against access by others in just a few steps and ensures that the bike stands securely even when fully loaded. It is operated conveniently via a foot pedal. A gas pressure spring holds the stand and pedal rattle-free under the loading area while riding.

### **Low centre of gravity**

The low centre of gravity of the cargo bed, together with the two battery compartments at the lowest point of the Cargobike, results in optimum weight distribution. This ensures safe cornering and at the same time dynamic handling even with a load.

### **Linkage steering with double stops**

The steering of the NC1 provides a direct steering feel thanks to the large steering angle and low-friction ball bearings. The double stops in the headset and on the steering linkage effectively prevent the front wheel from turning over, even in tight parking manoeuvres.

### **Steering damper**

A maintenance-free steering damper in the headset of the fork effectively prevents rocking thanks to CANE CREEK's patented Visco system and increases comfort and riding safety even at high speeds.

### **Stable 4-piston brake**

The stable MAGURA brake system with increased braking power and discs and pads specially optimised for e-bikes ensures the best performance in all situations.

### **Large-volume tyres**

Cargo bikes require special, heavy-duty tyres. The pick-up tyres from SCHWALBE with their rubber compound adapted to cargo bikes and wide cross-section ensure comfort and safety on the road.

### **High-quality lighting**

The bright SUPERNOVA Mini2 headlight and the integrated BUSCH&MÜLLER LED rear light in the mudguard ensure optimum visibility and safety in road traffic.

### **Easy-to-maintain cables and wires**

NICOLAI products are designed for durability and we avoid integrated cable routing as far as possible. If something does break, it can be repaired efficiently thanks to the maintenance-friendly design and routing of the cables and lines.

# NC1

## Prices 2023

NC1 base price (texture black matt, enviolo manual, 750Wh battery)	7699,00 €
Gear shift ENVIOLLO AutomatIQ	299,00 €
ROHLOFF Speedhub 500/14 manual	1299,00 €
ROHLOFF E14	1599,00 €
3X3 NINE Hub manual	949,00 €
3X3 NINE Hub e-shift	1099,00 €
Additional battery BOSCH PowerTube 750Wh	1049,00 €
Powder coating in desired colour	299,00 €
Luggage carrier RACKTIME Stand It	89,00 €
BOSCH Connect Module GPS Tracker	139,00 €
Panniers ORTLIEB Gravel Pack	130,00 €
Delivery within Germany	220,00 €
Delivery within and outside EU	Current prices on request
Further accessories	on request
Prices are subject to change at short notice	

Frame sizes	unsize*
A Top tube length	598 mm
B Seat tube length	480 mm
C1 Head tube length	126 mm
C2 Head tube length	782 mm
D Wheel base	2045 mm
E Head angle	72 °
F Seat angle	73 °
G Bottom bracket drop	64 mm
H Chain stay length	450 mm
I Seatpost diameter	30.9 mm
L Fork offset	38 mm
O Standover   Crotch clearance	520 mm
R Stack	698 mm
Q Reach	398 mm
U Cargo area	700x500 mm

\*Subject to change without notice | Subject to alteration

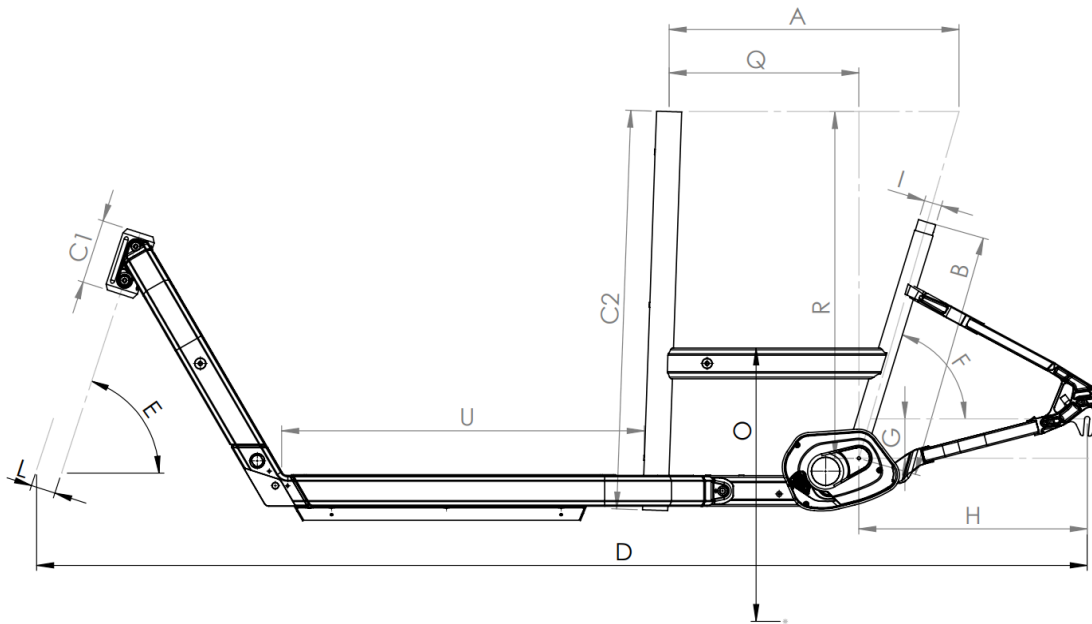

## NC1 Equipment

- **Frame** 7020-T6 ALUMINIUM, powder coated
- **Motor** BOSCH Performance Line CX (25 km/h, 250 Watt)
- **Battery** 1x BOSCH PowerTube 750
- **Display** BOSCH Kiox 300
- **Gear shift** ENVILO CA manual, heavy duty version
- **Front wheel hub** DT Swiss Nabe 370 Hybrid 6-Loch 36L 15x100
- **suspension fork** SR Suntour Mobie 20" A32
- **Headsets** CANE CREEK visco set / Ergotec angle limiting
- **Front tyres** SCHWALBE pickup 55-406
- **Rear tyres** SCHWALBE pickup 65-584
- **Tubes** SCHWALBE AV
- **Rims** RYDE Andra 40
- **Crank** MIRANDA Kappa 160mm
- **Belt drive** GATES Carbon Drive CDX, 50/24t, belt 120t
- **Saddle** SQLab 601, 160mm
- **Seatpost** BIKEYOKE Devine, lowerable via handlebar lever
- **Pedals** M-Wave Steady flat 3
- **Handlebar** SQLab 30X, 720mm width
- **Stem** NICOLAI 35mm, 31,8mm
- **Grips** SQLab 70X
- **Brakes** MAGURA CMe (4 pistons)
- **Headlight** SUPERNOVA Mini2
- **Rear light** BUSCH&MÜLLER Xeltec
- **Mudguards** SKS A65R
- **Stand** NICOLAI
- **Lock** NICOLAI (integrated in stand)

- **Charger** BOSCH 4A Charger
  
- **Dimensions** NC1 Length 266 cm x width 74 cm
- **Dimensions loading area** Length 70 cm x width 50 cm
- **Permissible total weight** 235 kg
- **Empty weight incl. 1x battery** 45 kg
- **Permissible weight of driver** 120 kg
- **Permissible load weight** 70 kg
- **Test standard** DIN 79010:2020